

IPv6 en Windows

Ignacio Cattivelli

Juan Jackson

Pablo García

Dual Stack Architecture

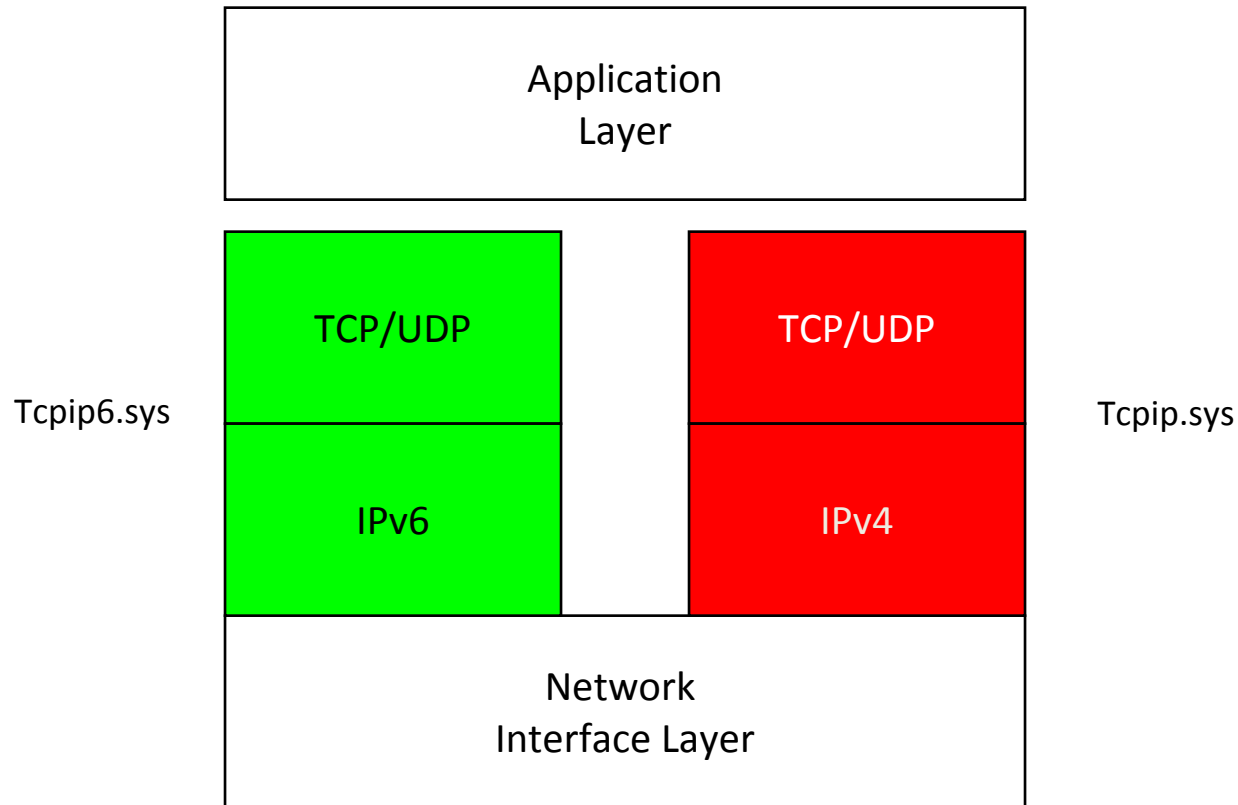

- In Windows XP and Windows Server 2003
- `Netsh int ipv6 [install|uninstall]`

Windows XP SP2 IPv6 Capabilities

- Limited Support:
 - Not on by default, must enable IPv6: netsh int ipv6 install
 - Basic native IPv6 capability, ISATAP, 6to4, Teredo
 - Autoconfiguration & well-known DNS IPs (FEC0)
 - Netsh int ipv6 commands required for config
 - ipconfig, route, ping and ping6, tracert, pathping, netstat
 - IE 6.0, IE7.0, telnet client, ftp clients
 - Filesharing via WebDAV only (e.g. over HTTP)
- Not supported:
 - DHCPv6 client, PPPv6 client
 - AD client protocols (RPC, LDAP, Kerb)
 - File sharing using IPv6 (SMB, NetBT)
 - IPHLPRAPI IPv6, e.g. can't add IPv6 routes via API

Windows Server 2003 SP2 IPv6 Capabilities

- Limited Support:
 - Windows XP SP2 IPv6 functionality, but also...
 - SMB client and server using native IPv6
 - Client won't ping dest first with IPv6 enabled
 - Telnet Server
 - RPC, Simple TCP/IP Services
- Not supported
 - Active Directory Protocols: LDAP, Kerberos, etc
 - SMB file sharing over IPv6 tunnel interfaces (e.g. ISATAP, 6to4)
 - FTP Server
 - IPHLPAPI IPv6, can't add IPv6 routes via API
 - Many command line tools that show or use explicit IP addresses

Install IPv6 protocol for Windows Server 2003:

- 1. Log on to the computer with a user account that has privileges to change network configuration.
- 2. Click **Start**, click **Control Panel**, and then double-click **Network Connections**.
- 3. Right-click any local area connection, and then click **Properties**.
- 4. Click **Install**.
- 5. In the Select Network Component Type dialog box, click **Protocol**, and then click **Add**.
- 6. In the Select Network Protocol dialog box, click **Microsoft TCP/IP version 6**, and then click **OK**.
- 7. Click **Close** to save changes to your network connection.

Install IPv6 protocol for Windows XP with SP2:

- 1. Log on to the computer with a user account that has privileges to change network configuration.
- 2. Click **Start**, click **Control Panel**, and then double-click **Network Connections**.
- 3. Right-click any local area connection, and then click **Properties**.
- 4. Click **Install**.
- 5. In the **Select Network Component Type** dialog box, click **Protocol**, and then click **Add**.
- 6. In the **Select Network Protocol** dialog box, click **Microsoft TCP/IP version 6**, and then click **OK**.
- 7. Click **Close** to save changes to your network connection.
- Alternately, from the Windows XP desktop, click **Start**, point to **Programs**, point to **Accessories**, and then click **Command Prompt**. At the command prompt, type **netsh interface ipv6 install**.

Dual IP Layer Architecture Traffic Types

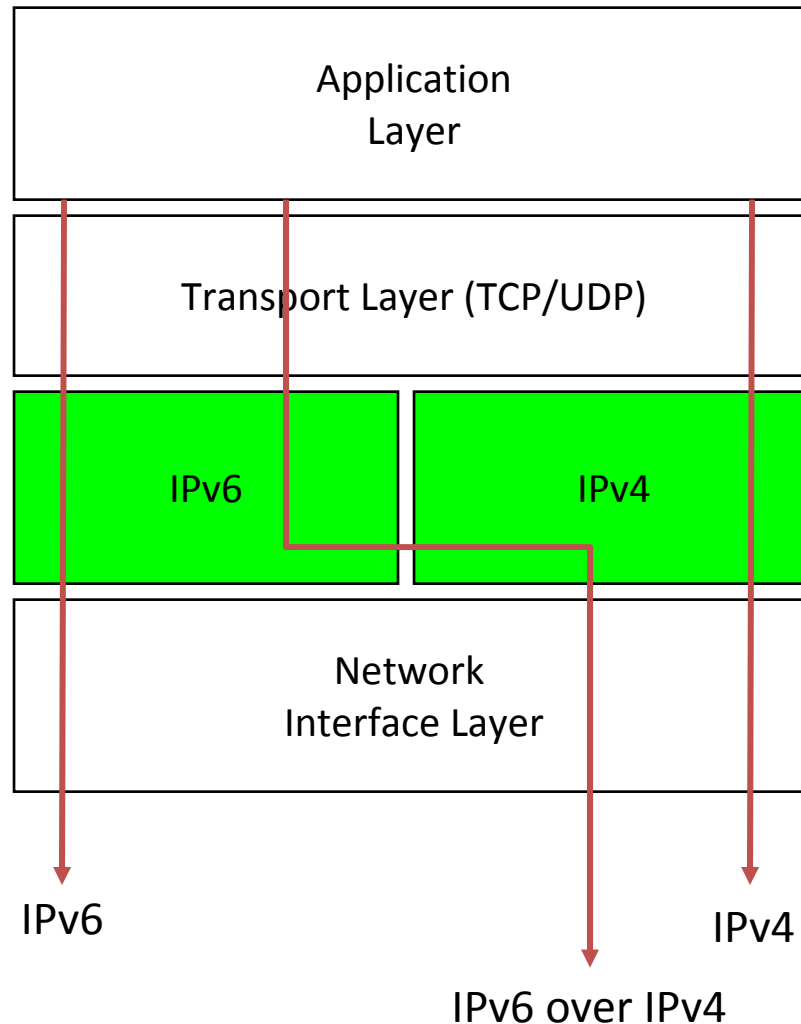

TCP/IP Protocol Architecture w/IPv6

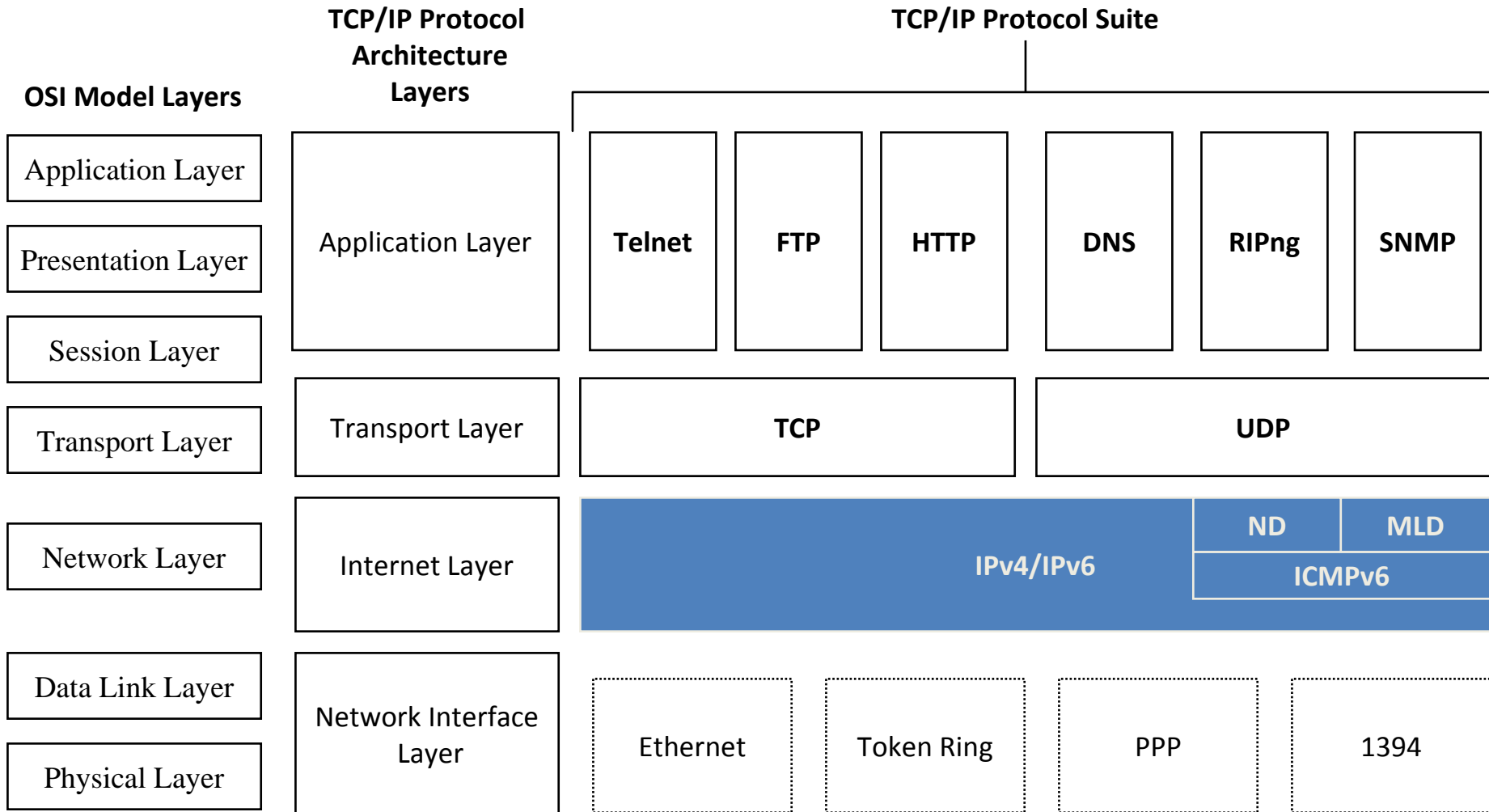

IPv6 Terminology

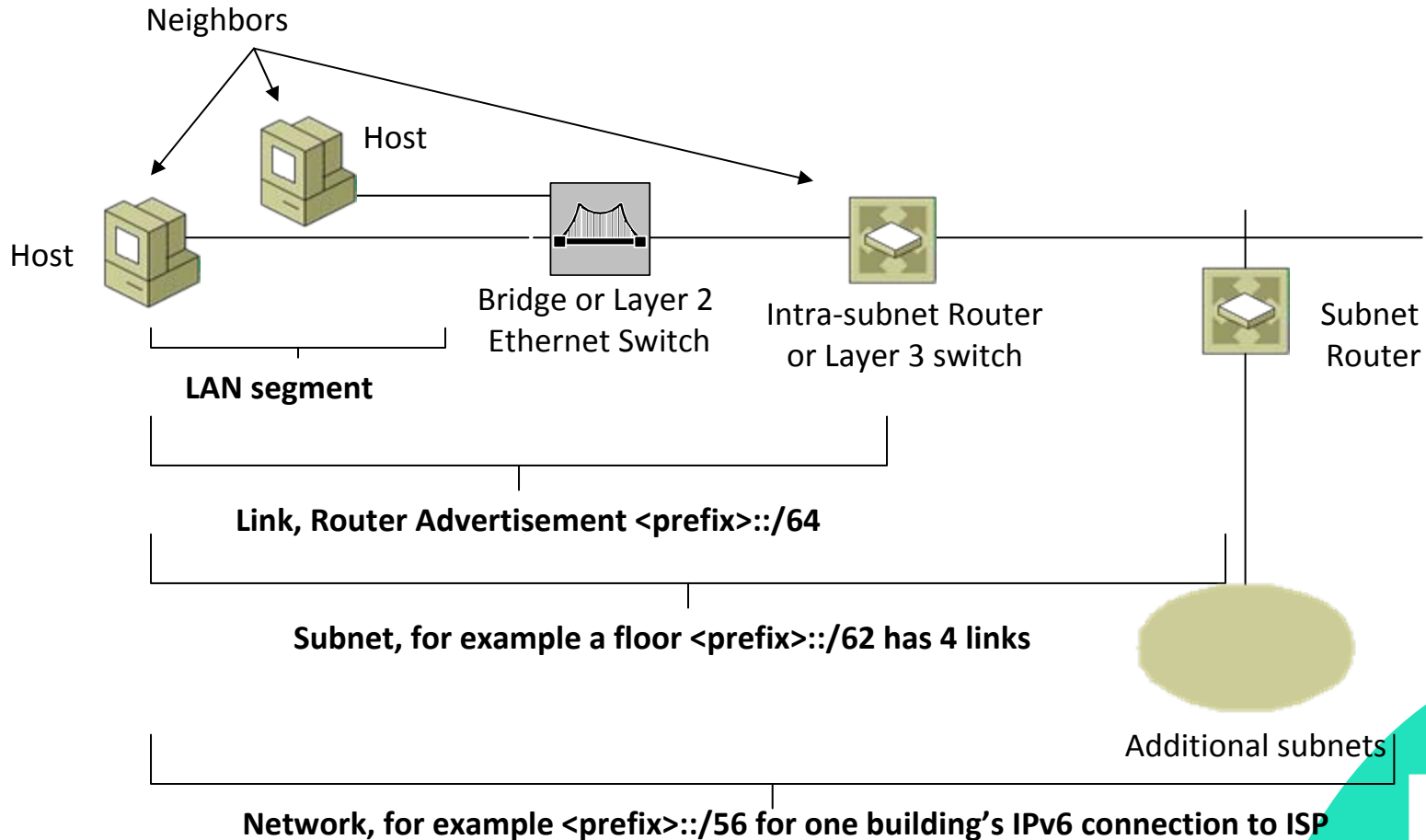

LIR/ISP prefix allocation: /48 or /56 for "end-site", "end-user"

Unicast IPv6 Addresses

- Global addresses
- Link-local addresses
- Site-local addresses

Global Addresses

- Address scope is the entire IPv6 Internet
 - Equivalent to public IPv4 addresses
- Defined in RFC 3587
- Structure
 - Global Routing Prefix
 - Subnet ID
 - Interface ID

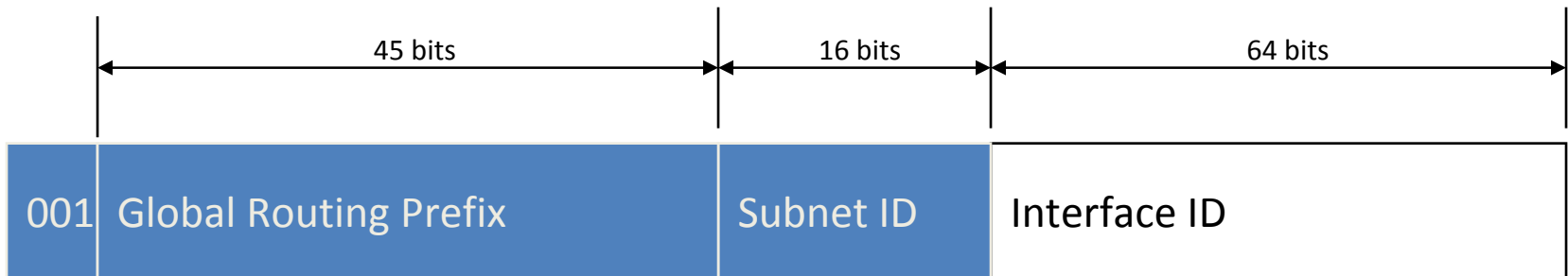

Link-Local Addresses

- Address scope is a single link
 - Equivalent to APIPA IPv4 addresses
- FE80::/64 prefix
- Used for:
 - Single subnet, routerless configurations
 - Neighbor Discovery processes

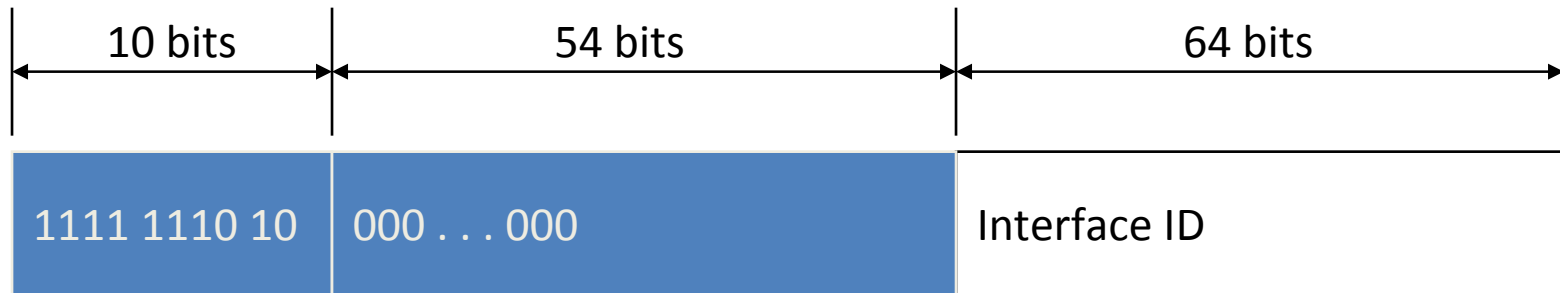

Site-Local Addresses

- Address scope is a single site
 - Equivalent to private IPv4 addresses
- FEC0::/10 prefix
- Used for intranets that are not connected to the IPv6 Internet
- Recently deprecated but supported for current implementations



Zone IDs for Link-Local and Site-Local Addresses

- Link-local and site-local addresses are ambiguous
 - Multiple links (common)
 - Multiple sites (uncommon)
- Zone ID is used to identify a specific link or site
 - Link-local address
 - Zone ID is typically set to the interface index of the sending interface
 - Site-local address
 - Zone ID is typically 1 unless multiple sites are used
- Examples:
 - ping fe80::2b0:d0ff:fee9:4143%3
 - traceroute fec0::f282:2b0:d0ff:fee9:4143%2



Example of IPv6 addresses

Tunnel adapter 6to4 Tunneling Pseudo-Interface:

Connection-specific DNS Suffix . : redmond.corp.microsoft.com

IP Address. : 2002:9d3b:9dd5::9d3b:9dd5

Tunnel adapter Automatic Tunneling Pseudo-Interface:

Connection-specific DNS Suffix . : redmond.corp.microsoft.com

IP Address. : fec0::f70f:0:5efe:157.59.157.213%1

IP Address. : 3ffe:8311:ffff:f70f:0:5efe:157.59.157.213

IP Address. : fe80::5efe:157.59.157.213%2

Default Gateway : fe80::5efe:157.56.253.8%2

Site Local Address

Global Address

Link Local Address

Ipconfig /all

```
Administrator: C:\Windows\System32\cmd.exe
Windows IP Configuration

Host Name . . . . . : WIN-5FBZIMB8X1N
Primary Dns Suffix . . . . . :
Mode Type . . . . . : Hybrid
IP Routing Enabled. . . . . : No
WINS Proxy Enabled. . . . . : No

Ethernet adapter Local Area Connection:

    Connection-specific DNS Suffix . :
    Description . . . . . : Intel 21140-Based PCI Fast Ethernet Adapter (Emulated)
    Physical Address. . . . . : 00-03-FF-4C-35-56
    DHCP Enabled. . . . . : Yes
    Autoconfiguration Enabled . . . . : Yes
    Link-local IPv6 Address . . . . . : fe80::782b:8b41:75c7:f52e%10(Preferred)
    IPv4 Address. . . . . : 192.168.131.70(Preferred)
    Subnet Mask . . . . . : 255.255.255.0
    Lease Obtained. . . . . : Sunday, July 06, 2008 6:55:03 PM
    Lease Expires . . . . . : Friday, July 11, 2025 1:43:34 PM
    Default Gateway . . . . . : 192.168.131.254
    DHCP Server . . . . . : 192.168.131.254
    DNS Servers . . . . . : 192.168.1.1
    NetBIOS over Tcpip. . . . . : Enabled

Tunnel adapter Local Area Connection* 8:

    Media State . . . . . : Media disconnected
    Connection-specific DNS Suffix . :
    Description . . . . . : isatap.<797E424D-79F8-4270-8B19-85AE6DAFDDBF>
    Physical Address. . . . . : 00-00-00-00-00-00-E0
    DHCP Enabled. . . . . : No
    Autoconfiguration Enabled . . . . : Yes

Tunnel adapter Local Area Connection* 9:

    Media State . . . . . : Media disconnected
    Connection-specific DNS Suffix . :
    Description . . . . . : Teredo Tunneling Pseudo-Interface
    Physical Address. . . . . : 02-00-54-55-4E-01
    DHCP Enabled. . . . . : No
    Autoconfiguration Enabled . . . . : Yes

C:\Windows\system32>
```

Ipconfig

```
Administrator: C:\Windows\System32\cmd.exe
C:\Windows\system32>ipconfig /?

USAGE:
    ipconfig [/allcompartments] [/? | /all |
        /renew [adapter] | /release [adapter] |
        /renew6 [adapter] | /release6 [adapter] |
        /flushdns | /displaydns | /registerdns |
        /showclassid adapter |
        /setclassid adapter [classid] ]

where
    adapter          Connection name
                    (wildcard characters * and ? allowed, see examples)

Options:
    /?              Display this help message
    /all            Display full configuration information.
    /allcompartments Display information for all compartments.
    /release        Release the IPv4 address for the specified adapter.
    /release6       Release the IPv6 address for the specified adapter.
    /renew          Renew the IPv4 address for the specified adapter.
    /renew6         Renew the IPv6 address for the specified adapter.
    /flushdns       Purges the DNS Resolver cache.
    /registerdns    Refreshes all DHCP leases and re-registers DNS names
    /displaydns     Display the contents of the DNS Resolver Cache.
    /showclassid   Displays all the dhcp class IDs allowed for adapter.
    /setclassid    Modifies the dhcp class id.

The default is to display only the IP address, subnet mask and
default gateway for each adapter bound to TCP/IP.

For Release and Renew, if no adapter name is specified, then the IP address
leases for all adapters bound to TCP/IP will be released or renewed.

For Setclassid, if no ClassId is specified, then the ClassId is removed.

Examples:
    > ipconfig          ... Show information
    > ipconfig /all     ... Show detailed information
    > ipconfig /renew   ... renew all adapters
    > ipconfig /renew EL* ... renew any connection that has its
                        name starting with EL
    > ipconfig /release *Con* ... release all matching connections,
                        eg. "Local Area Connection 1" or
                        "Local Area Connection 2"
    > ipconfig /allcompartments ... Show information about all
```

Automatic Tunneling Technologies

- 6to4
 - Allows IPv4/IPv6 hosts to communicate across the IPv4 Internet using public IPv4 addresses
- Teredo (IPv6 NAT Traversal)
 - Allows IPv4/IPv6 hosts to communicate across the IPv4 Internet across NATs
- ISATAP
 - Allows IPv4/IPv6 hosts to communicate across a private IPv4 intranet

Práctico, configuración de:

- 1 – Configurar dirección IP
- 2 – DNS
- 3 – DHCP
- 4 – Internet Information Server
- 5 – Herramientas de diagnóstico